

TONDINA POP 4 legs

5043-4LGP

Design Favaretto&Partners

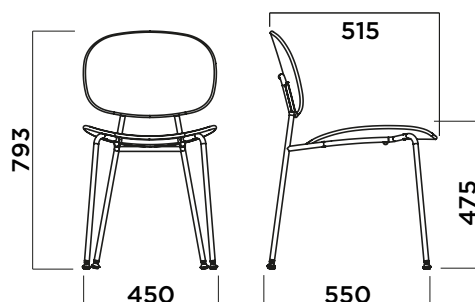

FRAME

TELAIO
BASTIDOR

Round tube diameter 16 mm, thickness 2 mm, accordingly Uni En 10305-3
Tubo tondo di diametro 16 mm, spessore 2mm, prodotto secondo norma Uni En 10305-3
Tubo redondo de 16 mm de diámetro, 2 mm de espesor, conforme a la norma UNI EN 10305-3.



OUTDOOR FRAME

TELAIO OUTDOOR
BASTIDOR PARA
EXTERIORES

Epoxy-polyester powder painted frame for outdoor, average thickness 50 μ .
Telaio per esterno verniciato a polveri epossipoliestere spessore medio 50 μ .
Estructura pintada epoxy para exteriores, espesor medio de 50 μ .



SEAT AND BACKREST

SEDUTA E SCHIENALE
ASIENTO Y RESPALDO

Polypropilene + Talc
Polypropilene + Talc
Polypropilene + Talc



FINISHING

FINITURA
ACABADO

Painted frame with epoxy-polyester powder with average thickness of 50 μ . Chrome plated frame with average thickness of 5 μ .
Telaio verniciato con polveri epossi-poliestere spessore medio di 50 μ . Telaio cromato con spessore medio 5 μ .
Bastidor con recubrimiento en polvo epoxi-poliéster con 50 μ de espesor medio. Bastidor cromado con 5 μ de espesor medio

CERTIFICATIONS

CERTIFICAZIONI
CERTIFICADOS



TONDINA POP 4 legs upholstered

5043-4LGT

Design Favaretto&Partners

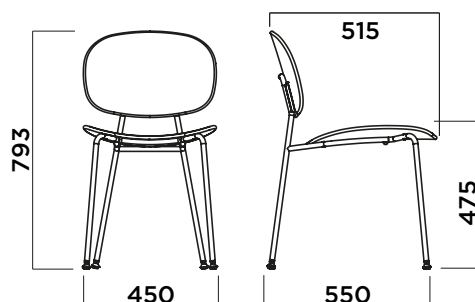

FRAME

TELAIO
BASTIDOR

Round tube diameter 16 mm, thickness 2 mm, accordingly Uni En 10305-3

Tubo tondo di diametro 16 mm, spessore 2mm, prodotto secondo norma Uni En 10305-3

Tubo redondo de 16 mm de diámetro, 2 mm de espesor, conforme a la norma UNI EN 10305-3.



UPHOLSTERY

TAPPEZZERIA
TAPIZADOS

- A Flash, Byte
- B Eco Leather
- C Patina, Step, Step Melange, Reflect
- D Revive
- E Field, Oceanic , Yoredale
- F Canvas, Glow, SteelCut Trio
- G Divina3, Divina Melange, Harald, Fiord, Planum
- H Full Leather

FINISHING

FINITURA
ACABADO

Painted frame with epoxy-polyester powder with average thickness of 50 μ . Chrome plated frame with average thickness of 5 μ

Telaio verniciato con polveri epossi-poliestere spessore medio di 50 μ . Telaio cromato con spessore medio 5 μ .

Bastidor con recubrimiento en polvo epoxi-poliéster con 50 μ de espesor medio. Bastidor cromado con 5 μ de espesor medio